

1 2 3 4 5 6 7 8

REVISIONS		
ISS	ZONE	DESCRIPTION\PER REQUEST\DATE

業務部

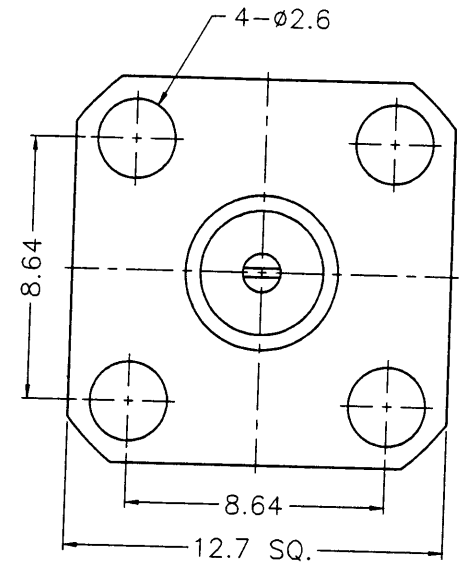
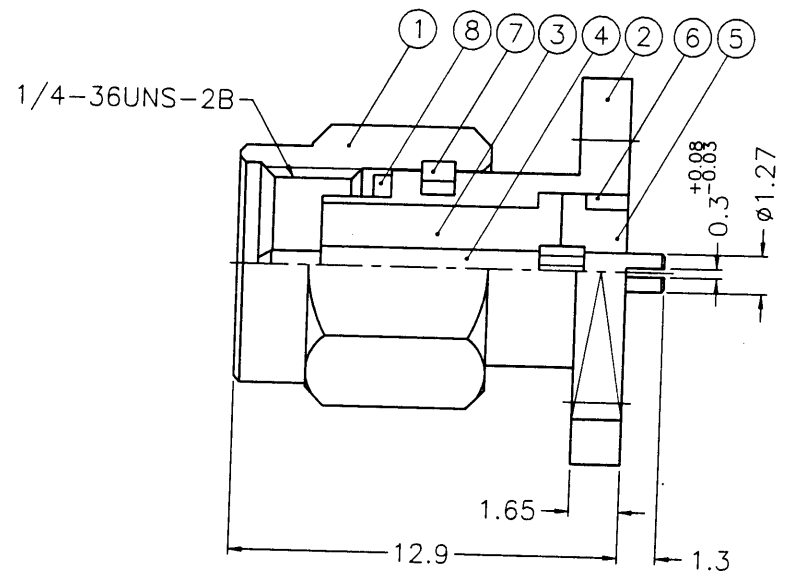

NOTES: FINISH (PLATING THICKNESS IN MICRO-INCHES)  
 1. BRASS PER QQ-B-626  
 2. STAINLESS STEEL PER QQ-S-764, TYPE 303  
 3. PASSIVATED PER QQ-P-35  
 4. BERYLLIUM COPPER PER QQ-C-530  
 5. GOLD PL. 50 MIN. THICK OVER NICKEL PL. 100 MIN. THICK OVER COPPER STRIKE  
 6. TEFLON MIL-P-19468

2000. 8. 05  
 設計部

NO.	DESCRIPTION	MATERIAL	FINISH	Q'TY	DRAWING NO.
8	GASKET	SILICONE	RED	1	GS-6/43X06
7	RETAINER RING	NOTE 4	NATURAL	1	SMA5000-4-B
6	RING	NOTE 2	NOTE 3	1	SMA7530-5-B
5	INSULATOR	NOTE 6	NATURAL	1	SMA7530-4T-50
4	CONTACT PIN	NOTE 1	MOTE 5	1	SMA5540-4-0.35
3	INSULATOR	NOTE 6	NATURAL	1	SMA5530-3T-50-B
2	BODY	NOTE 2	NOTE 3	1	SMA5530-2-A
1	SHELL	NOTE 2	NOTE 3	1	SMA5000-1-C

DIMENSIONS ARE IN MILLIMETERS  
 UNLESS OTHERWISE SPECIFIED TOLERANCES  
 0.5-6 = ±0.2  
 6-30 = ±0.4  
 30-120 = ±0.6  
 120-315 = ±1  
 315-1000 = ±1.6  
 1000-2000 = ±2.4

PART NO.	
APPROVED	DATE 08-02-00'
CHECKED	DATE 08-02-00'
DRAWN	DATE 08-02-00'

Amphenol - Kai Jack	
TAINAN TAIWAN	
TITLE	SMA PANEL RECEPT. PLUG
DRAWING NO.	KJ-SMA1551C1-S/PT50G-0.3-50
FILE NO.	F:\DWG\SMA\1551C1\03-50\SPT50G

F  
E  
D  
C  
B  
A

F  
E  
D  
C  
E  
A